

PROPOSED GROUND FLOOR PLAN

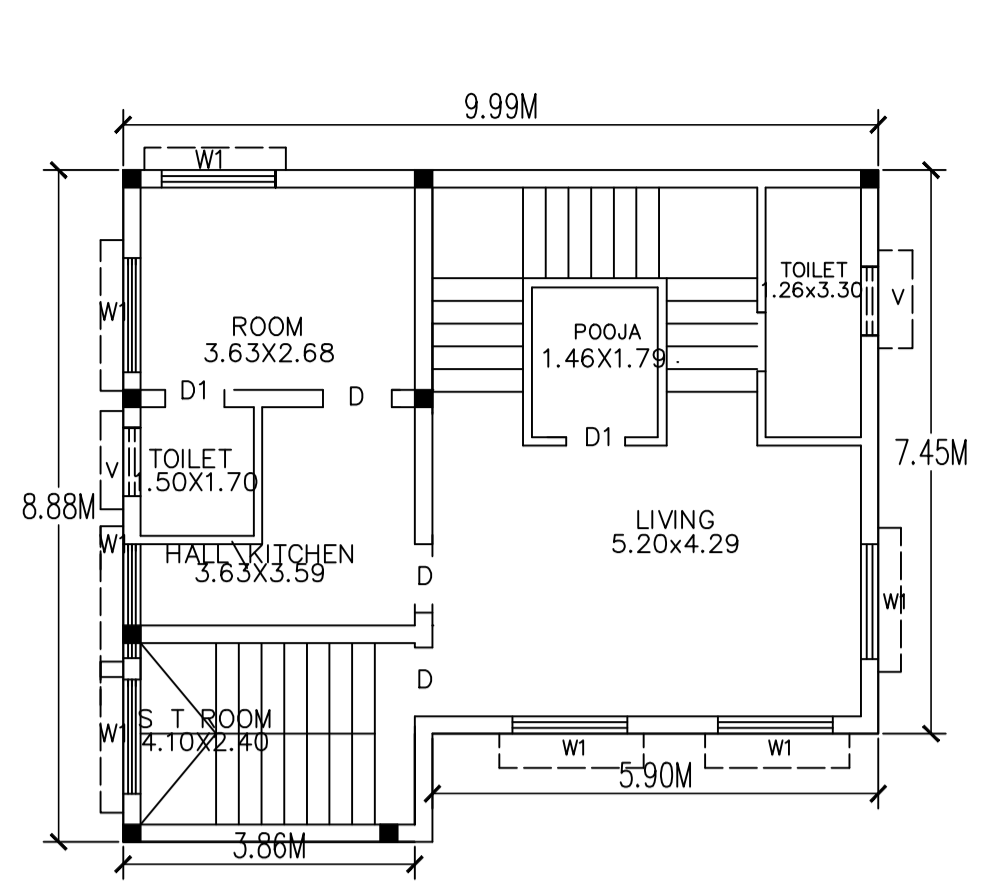

PROPOSED FIRST FLOOR PLAN

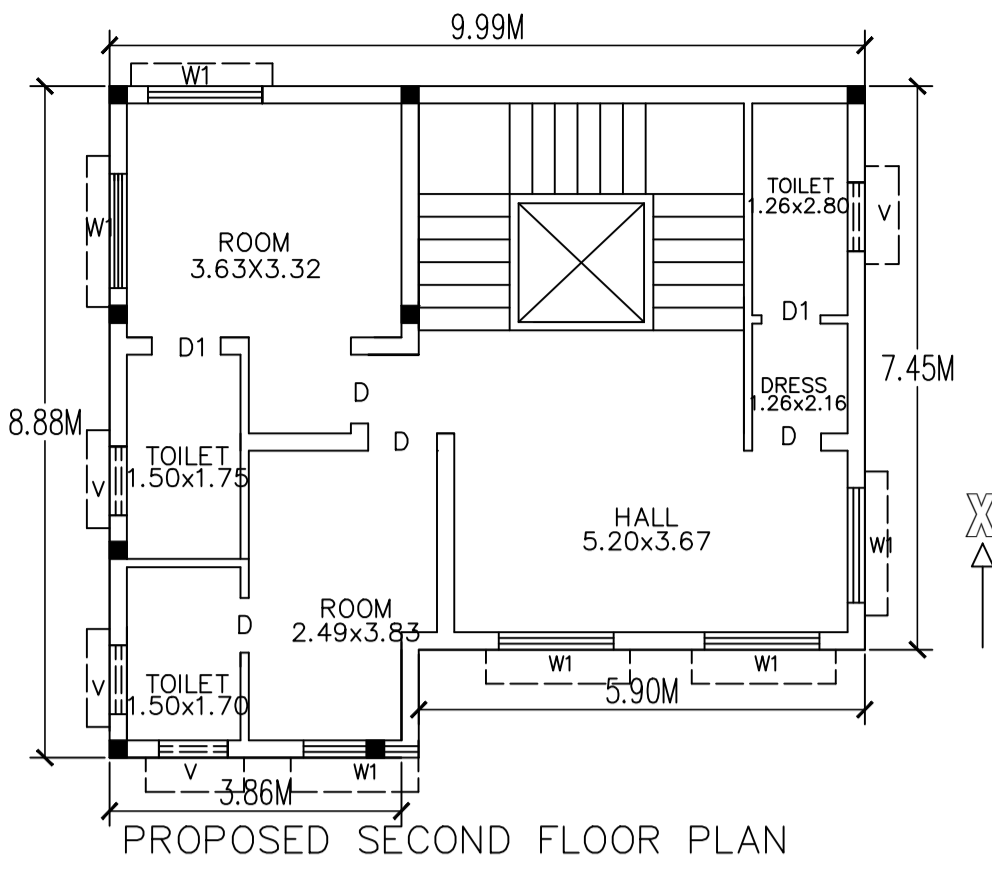

PROPOSED SECOND FLOOR PLAN

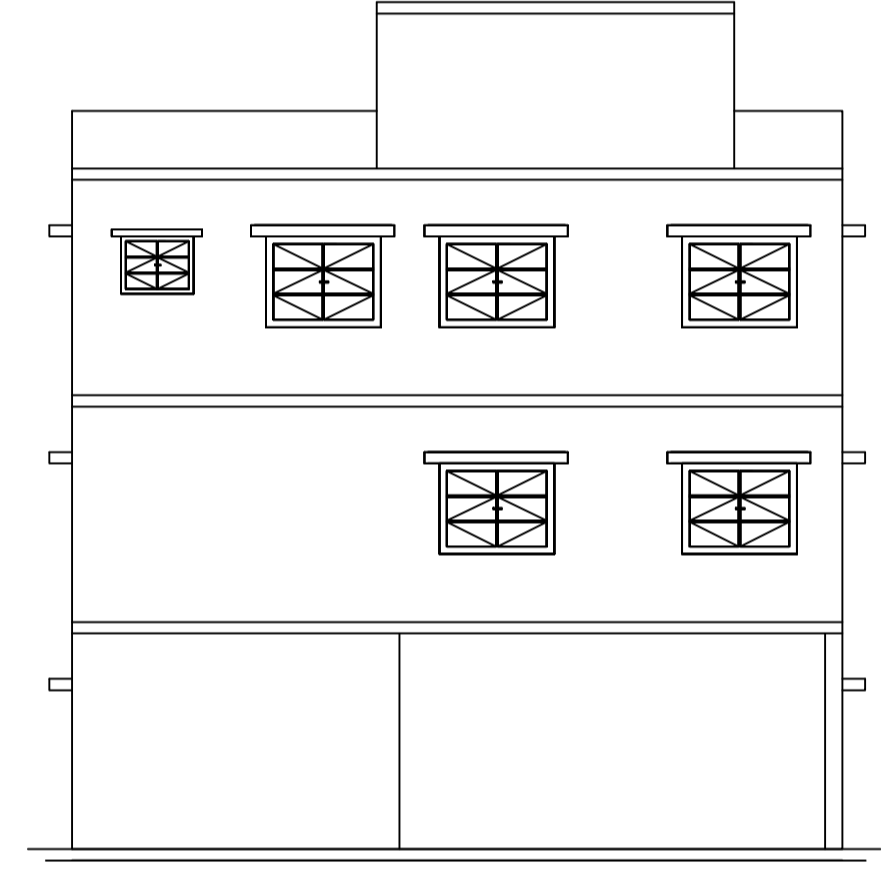

FRONT ELEVATION

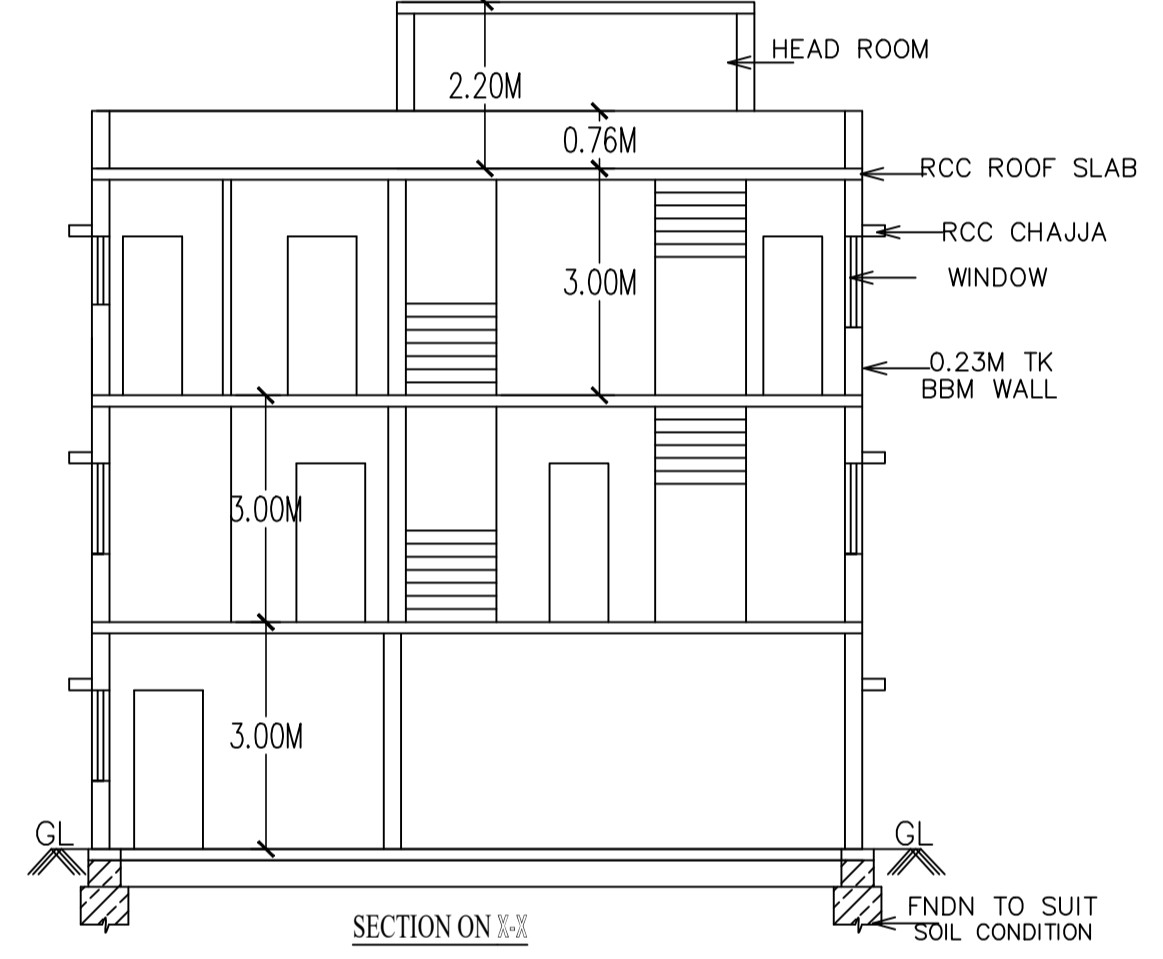

SECTION ON X-X

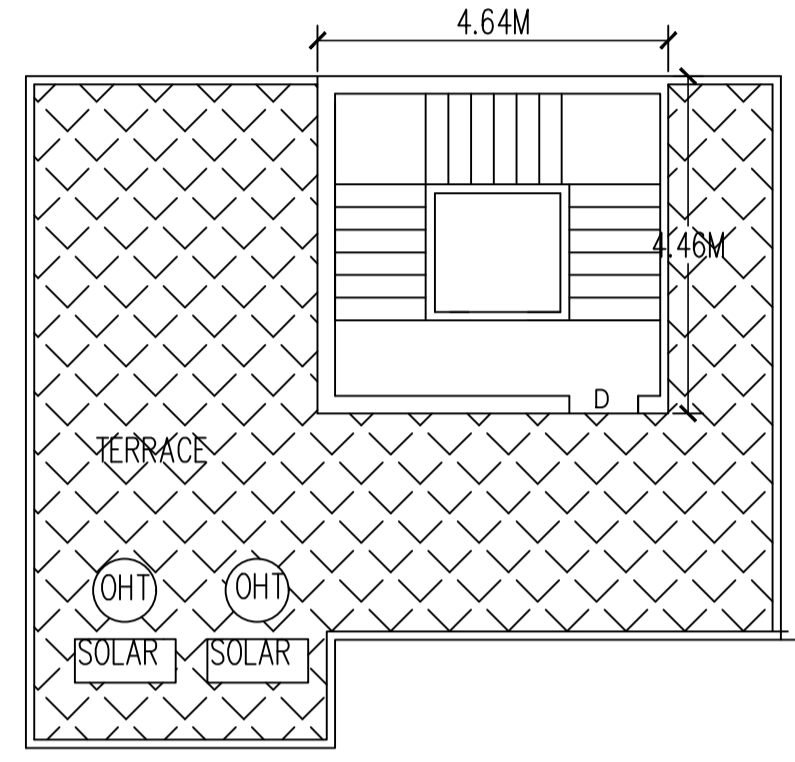

PROPOSED TERRACE FLOOR PLAN

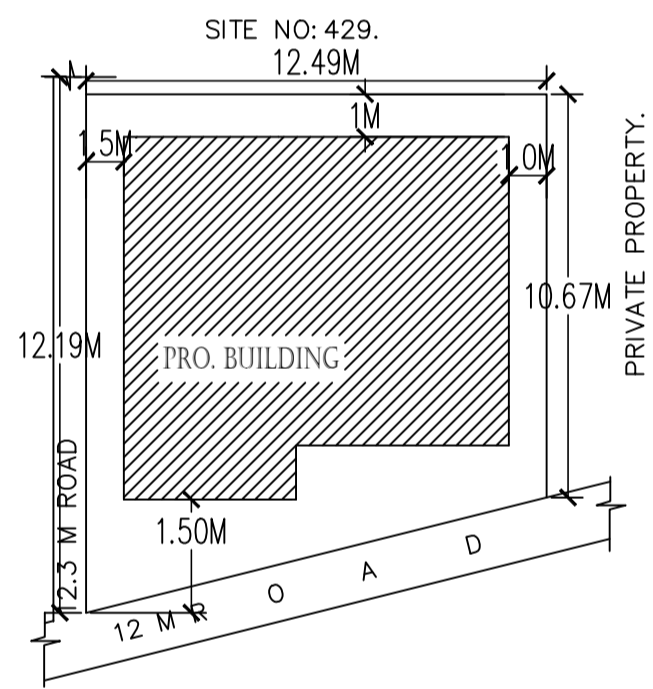

SITE PLAN

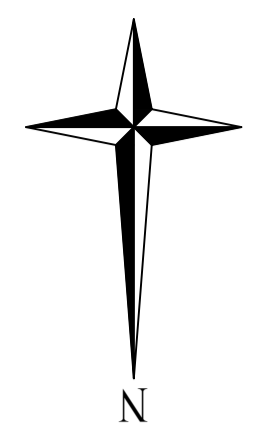

Color Notes

COLOR INDEX	
[Line Style]	PLOT BOUNDARY
[Line Style]	ABUTTING ROAD
[Line Style]	PROPOSED WORK (COVERAGE AREA)
[Line Style]	EXISTING (To be retained)
[Line Style]	EXISTING (To be demolished)

Approval Condition :

This Plan Sanction is issued subject to the following conditions :

- Sanction is accorded for the Residential Building at 430 , RHBCS LAYOUT, A BLOCK , NAGARABHAVI, Bangalore.
- Consist of 1Ground + 2 only.
- Sanction is accorded for Residential use only. The use of the building shall not be deviated to any other use.
- 3.44.75 area reserved for car parking shall not be converted for any other purpose.
- Development charges towards increasing the capacity of water supply, sanitary and power main has to be paid to BWSSB and BESCOM if any.
- Necessary ducts for running telephone cables, cubicles at ground level for postal services & space for dumping garbage within the premises shall be provided.
- The applicant shall INSURE all workmen involved in the construction work against any accident / untoward incidents arising during the time of construction.
- The applicant shall not stock any building materials / debris on footpath or on roads or on drains. The debris shall be removed and transported to near by dumping yard.
- The applicant shall maintain during construction such barricading as considered necessary to prevent dust, debris & other materials endangering the safety of people / structures etc. in & around the site.
- The applicant shall plant at least two trees in the premises.
- Permission shall be obtained from forest department for cutting trees before the commencement of the work.
- License and approved plans shall be posted in a conspicuous place of the licensed premises. The building license and the copies of sanctioned plans with specifications shall be mounted on a frame and displayed and they shall be made available during inspections.
- If any owner / builder contravenes the provisions of Building Bye-laws and rules in force, the Architect / Engineer / Supervisor will be informed by the Authority in the first instance, warned in the second instance and cancel the registration if the same is repeated for the third time.
- Technical personnel, applicant or owner as the case may be shall strictly adhere to the duties and responsibilities specified in Schedule - IV (Bye-law No. 3.6) under sub section IV-8 (a) to (k).
- The building shall be constructed under the supervision of a registered structural engineer.
- On completion of foundation or footings before erection of walls on the foundation and in the case of columnar structure before erecting the columns "COMMENCEMENT CERTIFICATE" shall be obtained.
- Drinking water supplied by BWSSB should not be used for the construction activity of the building.
- The applicant shall ensure that the Rain Water Harvesting Structures are provided & maintained in good repair for storage of water for non potable purposes or recharge of ground water at all times having a minimum total capacity mentioned in the Bye-law 32(a).
- If any owner / builder contravenes the provisions of Building Bye-laws and rules in force, the authority will inform the same to the concerned registered Architect / Engineers / Supervisor in the first instance, warn in the second instance and cancel the registration if the same is repeated for the third time.
- The Builder / Contractor / Professional responsible for supervision of work shall not shall not materially and structurally deviate the construction from the sanctioned plan, without previous approval of the authority. They shall explain to the owners about the risk involved in contravention of the provisions of the Act, Rules, Bye-laws, Zoning Regulations, Standing Orders and Policy Orders of the BBMP.
- In case of any false information, misrepresentation of facts, or pending court cases, the plan sanction is deemed cancelled.
- Special Condition as per Labour Department of Government of Karnataka vide ADDENDUM (Hosadaagi/Hoodagi) Letter No. LD/95/LET/2013, dated: 01-04-2013 :

AREA STATEMENT (BBMP)		VERSION NO. : 1.0.13
PROJECT DETAILS:		VERSION DATE: 26/06/2020
Authority: BBMP	Plot Use: Residential	
Inward No: BBMP/Ad.Com./RJH/051120-21	Plot SubUse: Plotted Resi development	
Application Type: Suvarna Parvangi	Land Use Zone: Residential (Main)	
Proposal Type: Building Permission	Plot/Sub Plot No.: 430	
Nature of Sanction: NEW	Khata No. (As per Khata Extract): 438/430	
Location: RING-III	Locality / Street of the property: RHBCS LAYOUT, A BLOCK, NAGARABHAVI	
Building Line Specified as per Z.R. NA		
Zone: Rajarajeshwari Nagar		
Ward: Ward-129		
Planning District: 301-Kengeri		
AREA DETAILS:		SQ.MT.
AREA OF PLOT (Minimum)	(A)	142.71
NET AREA OF PLOT	(A-Deductions)	142.71
COVERAGE CHECK		
Permissible Coverage area (75.00 %)		107.03
Proposed Coverage Area (57.19 %)		81.62
Achieved Net coverage area ( 57.19 % )		81.62
Balance coverage area left ( 17.81 % )		25.41
FAR CHECK		
Permissible F.A.R. as per zoning regulation 2015 ( 1.75 )		249.74
Additional F.A.R. within Ring I and II ( for amalgamated plot - )		0.00
Allowable TDR Area (60% of Perm.FAR )		0.00
Premium FAR for Plot within Impact Zone ( - )		0.00
Total Perm. FAR area ( 1.75 )		249.74
Residential FAR (100.00%)		151.11
Proposed FAR Area		151.11
Achieved Net FAR Area ( 1.06 )		151.11
Balance FAR Area ( 0.69 )		98.63
BUILT UP AREA CHECK		
Proposed BuiltUp Area		262.95
Achieved BuiltUp Area		262.95

Approval Date : 08/24/2020 1:18:41 PM

Payment Details							
Sr No.	Challan Number	Receipt Number	Amount (INR)	Payment Mode	Transaction Number	Payment Date	Remark
1	BBMP/9142/CH/20-21	BBMP/9142/CH/20-21	1288	Online	10843832021	08/06/2020 4:05:19 PM	-
	No.	Head			Amount (INR)	Remark	
	1	Scrutiny Fee			1288		

The plans are approved in accordance with the acceptance for approval by the Assistant Director of town planning (RR NAGAR) on date: 24/08/2020 vide lp number: BBMP/Ad.Com./RJH/0511/20-21 subject to terms and conditions laid down along with this building plan approval.

This approval of Building plan/ Modified plan is valid for two years from the date of issue of plan and building licence by the competent authority.

ASSISTANT DIRECTOR OF TOWN PLANNING (RR NAGAR)  
BHRUHAT BENGALURU MAHANAGARA PALIKE

OWNER / GPA HOLDER'S SIGNATURE  
OWNER'S ADDRESS WITH ID NUMBER & CONTACT NUMBER :  
HARISH.G & SHRUTHI.T.V NO:17, KRISHNAPPA GARDEN, K CROSS, 6TH CROSS, NEAR LAKSHMI THEATER, N G PALYA

ARCHITECT/ENGINEER /SUPERVISOR'S SIGNATURE  
SUSHMITHA S #307, 2nd stage,6th block, nagarabhavi  
BCC/BL-3.6/4335/2018-19

PROJECT TITLE :  
PROPOSED RESIDENTIAL BUILDING FOR HARISH.G & SHRUTHI.T.V, ON SITE NO:430, KHATHA NO:438/430, RHBCS LAYOUT, A BLOCK, NAGARABHAVI, BANGALORE WARD NO:129.

DRAWING TITLE : 431914182-20-08-2020  
02-44-01\$ \_\$35X41 G2 W129HARISH

SHEET NO : 1

Block USE/SUBUSE Details				
Block Name	Block Use	Block SubUse	Block Structure	Block Land Use Category
A (A)	Residential	Plotted Resi development	Bldg upto 11.5 mt. Ht.	R

Required Parking (Table 7a)								
Block Name	Type	SubUse	Area (Sq.mt.)	Units	Car			
				Reqd.	Prop.	Reqd./Unit	Reqd.	Prop.
A (A)	Residential	Plotted Resi development	50 - 225	1	-	1	1	-
Total :			-	-	-	-	1	2

Parking Check (Table 7b)						
Vehicle Type	Reqd.			Achieved		
	No.	Area (Sq.mt.)		No.	Area (Sq.mt.)	
Car	1	13.75	2	2	27.50	
Total Car	1	13.75	2	2	27.50	
TwoWheeler	-	13.75	0	0	0.00	
Other Parking	-	-	-	-	17.25	
Total					44.75	

FAR & Tenement Details							
Block	No. of Same Bldg	Total Built Up Area (Sq.mt.)	Deductions (Area in Sq.mt.)		Proposed FAR Area (Sq.mt.)	Total FAR Area (Sq.mt.)	Tnmt (No.)
			StairCase	Parking			
A (A)	1	262.95	67.09	44.75	151.11	151.11	02
Grand Total:	1	262.95	67.09	44.75	151.11	151.11	2.00

Block :A (A)						
Floor Name	Total Built Up Area (Sq.mt.)	Deductions (Area in Sq.mt.)		Proposed FAR Area (Sq.mt.)	Total FAR Area (Sq.mt.)	Tnmt (No.)
		StairCase	Parking			
Terrace Floor	20.69	20.69	0.00	0.00	0.00	00
Second Floor	80.32	14.29	0.00	66.03	66.03	00
First Floor	80.32	23.40	0.00	56.92	56.92	01
Ground Floor	81.62	8.71	44.75	28.16	28.16	01
Total:	262.95	67.09	44.75	151.11	151.11	02
Total Number of Same Blocks :	1					
Total:	262.95	67.09	44.75	151.11	151.11	02

SCHEDULE OF JOINERY:				
BLOCK NAME	NAME	LENGTH	HEIGHT	NOS
A (A)	D1	0.78	2.10	04
A (A)	D	0.91	2.10	08
A (A)	D1	0.91	2.10	02

SCHEDULE OF JOINERY:				
BLOCK NAME	NAME	LENGTH	HEIGHT	NOS
A (A)	W1	1.51	1.20	24

UnitBUA Table for Block :A (A)						
FLOOR	Name	UnitBUA Type	UnitBUA Area	Carpet Area	No. of Rooms	No. of Tenement
GROUND FLOOR PLAN	SPLIT 1	FLAT	36.87	31.05	3	1
FIRST FLOOR PLAN	SPLIT 22	FLAT	160.64	143.69	6	1
SECOND FLOOR PLAN	SPLIT 22	FLAT	0.00	0.00	7	0
Total:	-	-	197.51	174.74	16	2